

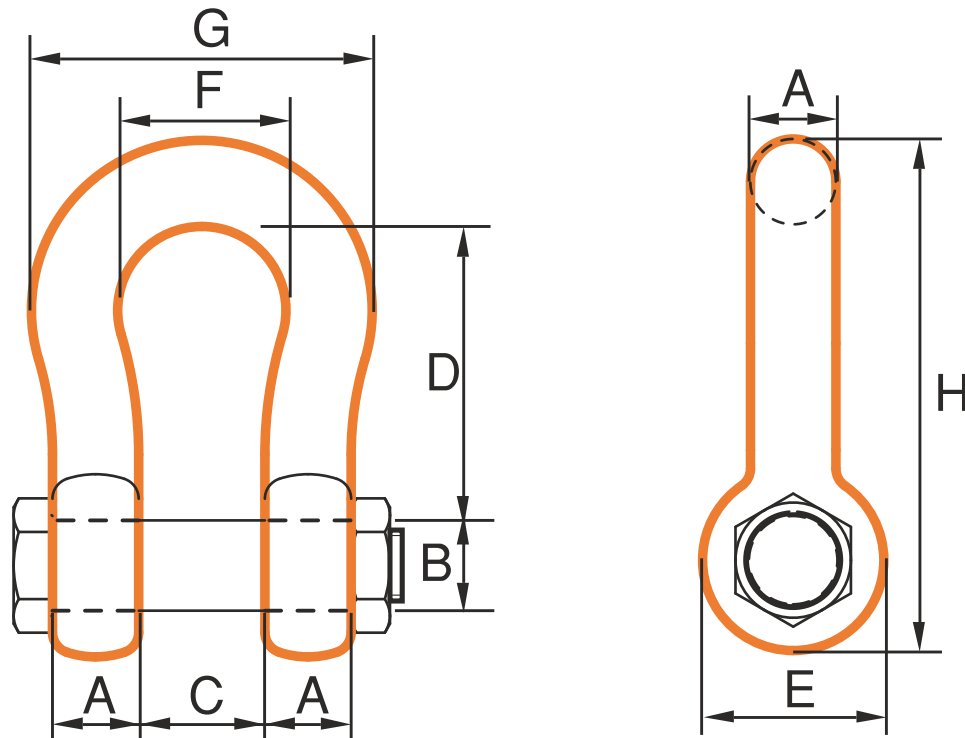

GN H9 Shackle – Mooring Chain



WLL	Weight	A	B	C	D	E	F	G	H
0.33	0.02	5	6	10	22	12	16	26	36
0.5	0.06	7	8	12	29	17	20	34	49
0.75	0.11	9	10	14	32	20	22	40	56
1	0.16	10	11	17	37	23	26	46	64
1.5	0.22	11	13	19	43	27	29	51	74
2	0.42	14	16	22	51	34	32	58	89
3.25	0.74	16	19	27	64	40	43	75	110
4.75	1.2	19	22	31	76	46	51	89	129
6.5	1.8	22	25	36	83	52	58	102	144
8.5	2.6	25	28	43	95	59	68	118	164
9.5	3.7	28	32	47	108	66	75	131	185
12	4.9	32	35	51	115	72	83	147	201
13.5	6.5	35	38	57	133	80	92	162	227
17	8.2	38	42	60	146	88	99	175	249
25	14	45	50	74	178	103	126	216	300
35	20	50	57	83	197	111	138	238	331
42.5	28	57	65	95	222	130	160	274	377
55	40	65	70	105	260	145	180	310	433
85	62	75	83	127	329	162	190	340	527

Weight unit is Kilograms. All measurements in mm. Measurements, weights, and drawings, are based on industry standards. Deviation margins need to be taken in mind, this is your own responsibility and not from Castle Hills AS.